

Portable Power Station

Model NO: EA3000-3072Wh-1BK

Product Instruction Manual

Please read the instructions carefully before use and follow the instructions

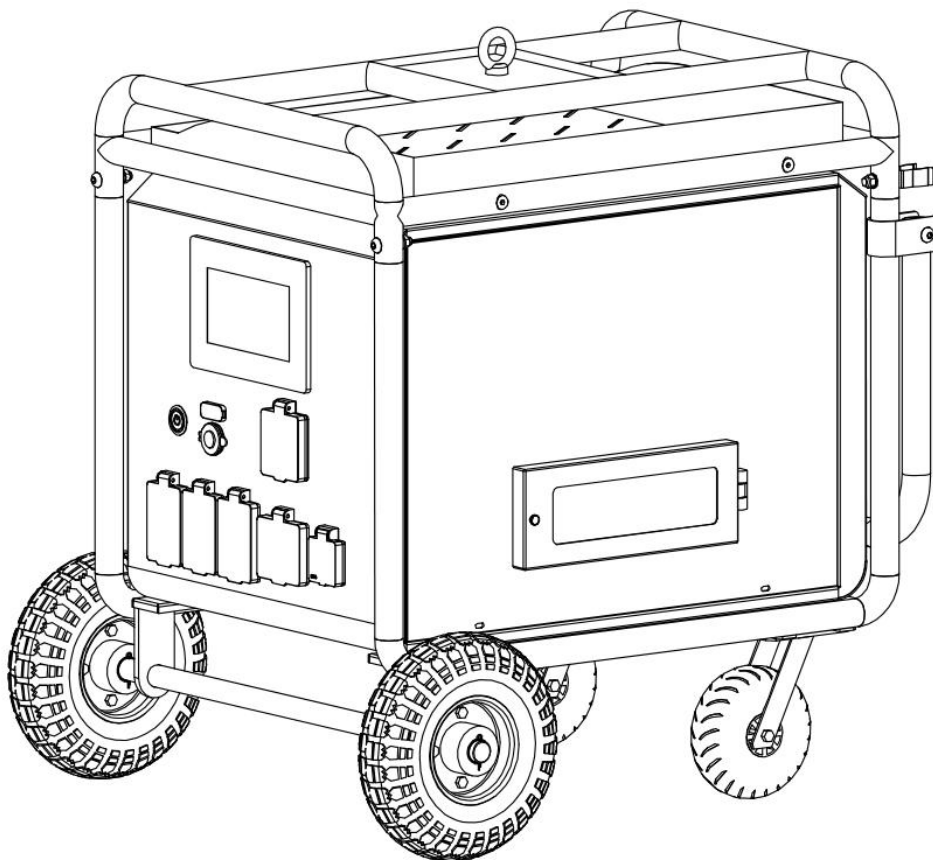

CEA Electric Co., Ltd

CONTENT

I、Product Use and Function Introduction.....	1-2
II、Product Introduction.....	3-10
1.Product Main Structure Composition.....	3
2.Panel Function Description.....	3-5
3.Display Interface Description.....	5-10
III、Technical Parameters.....	11
IV、Operation and Usage.....	12
1. Steps for the First Start of Portable Power Station.....	12
2.Charging Steps.....	12
3.AC Output Onload Usage.....	13
4.DC/USB Output Onload Usage.....	13
5. Expandable Battery Usage.....	13
V、Fault Code Comparison Table.....	14-16
VI、Product Maintenance.....	17
VII、Common Troubleshooting.....	17-19
VIII、Warnings and Precautions.....	20-22
IX、Product Packaging List.....	23

I、Product Use and Function Introduction

- **Product Name:** Potable Power Station
- **Model/Specification:** EA3000-3072Wh-1BK
- **Application and Function Introduction:** Transform LiFeP04 DC to AC sine wave by inverter. When the product is out of power, it can be charged by mains and PV. Without Mains, this product can output AC to charge devices with corresponding power such as fridges, electric hammers, induction cookers, rice makers, fans, washing machines, TV, and air-conditioner. This product supports PV charging while discharging. Its structure meets UL2743 standards and can replace the gasoline generator for outdoor emergency work on rainy days. The product supports six expandable external batteries at maximum, reaching 35.84KWH with a more durable loaded application. This product is equipped with two 10-inch foam wheels and two 7-inch universal wheels with brakes, making it to be moved easier. On top of the product, we designed a hook for safe lifting and handling. Besides, boxes on the top and side allow users to put tools and accessories in outdoor works. The main screen is a 7-inch high-resolution capacitance touch screen with characteristics like anti-glare, high-definition, and high sensitivity. All port covers are plastic. All output AC sockets are independently installed with overload, short circuit protectors, and the GFCI leakage protection socket to avoid safety risks during

the use. The product has functions like output overload, short circuits, and high temperature.

II、Product Introduction

1. Product Main Structure Composition

The portable power station is mainly composed of a metal protection frame, metal shell, PV reverse control machine, touch screen, USB/DC panel, LiFeP04 battery, and other main accessories.

2. Description of Panel Functions

2.1 Front Panel

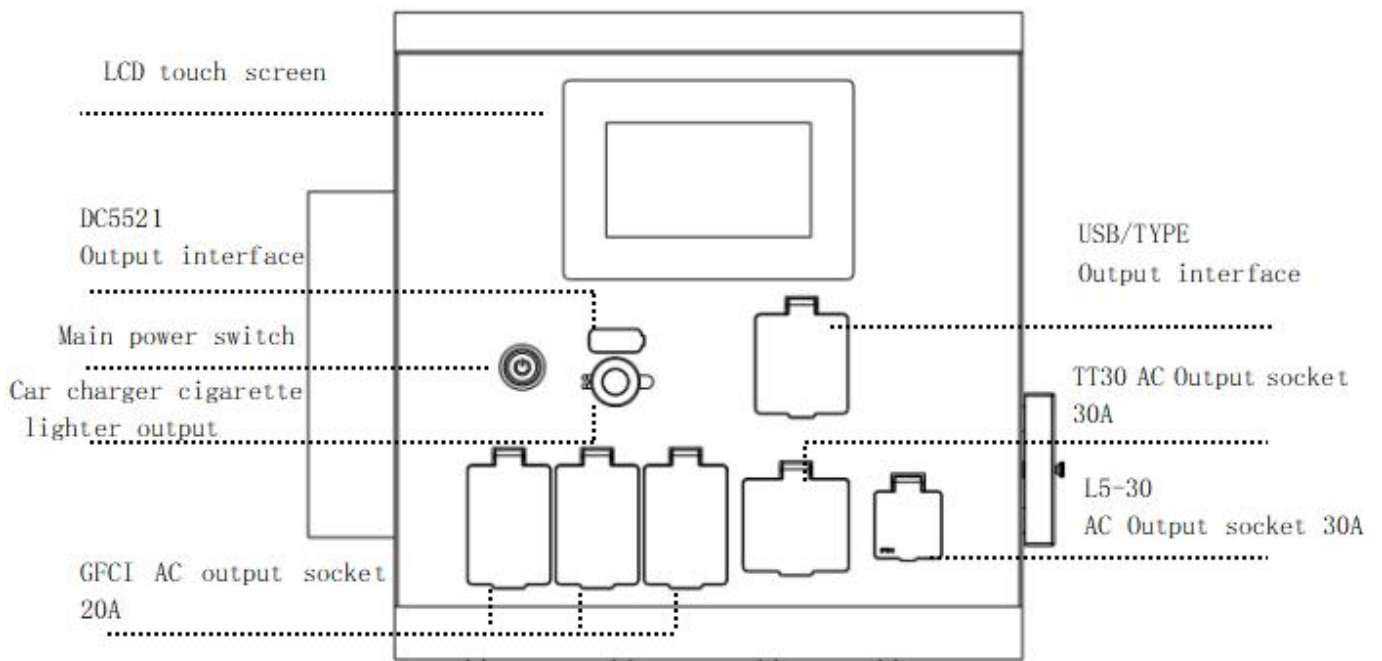

2.2 Rear panel

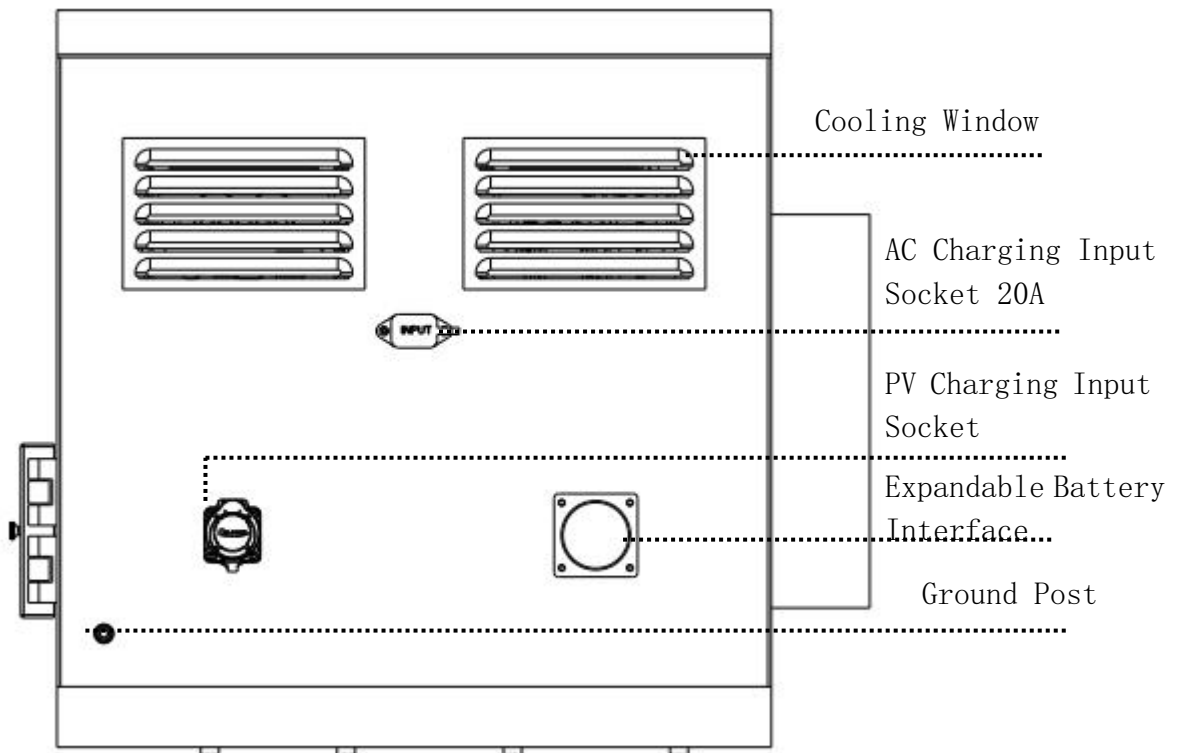

2.3 Left Door

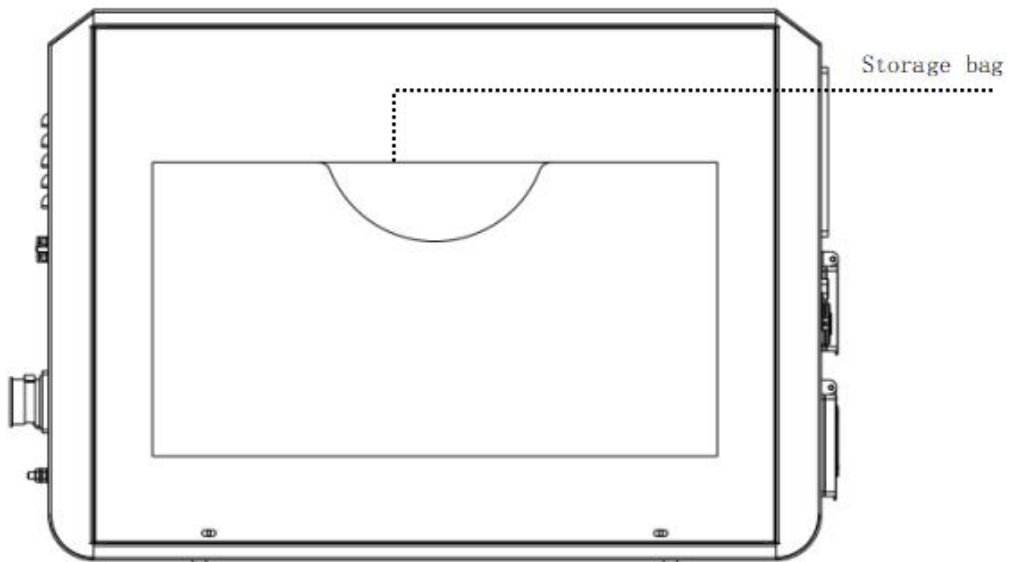

2.4 Right Door

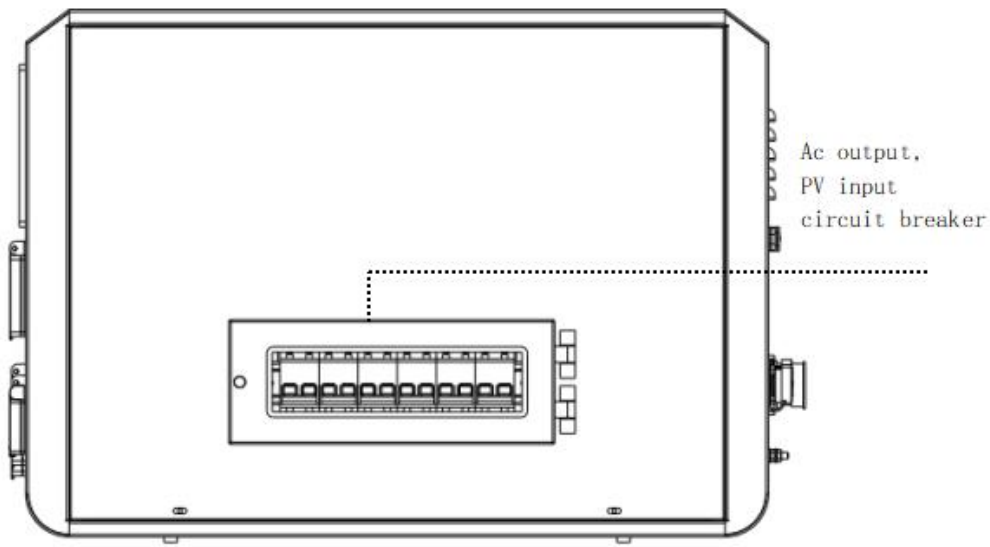

3. Display Interface Description

3.1 Home Page

Total Battery Level and Expandable Battery Information Button

Parameter Setting Button

Back Home Button

Remaining Charging Time

Remaining Time on Load

DC/USB Output Switch

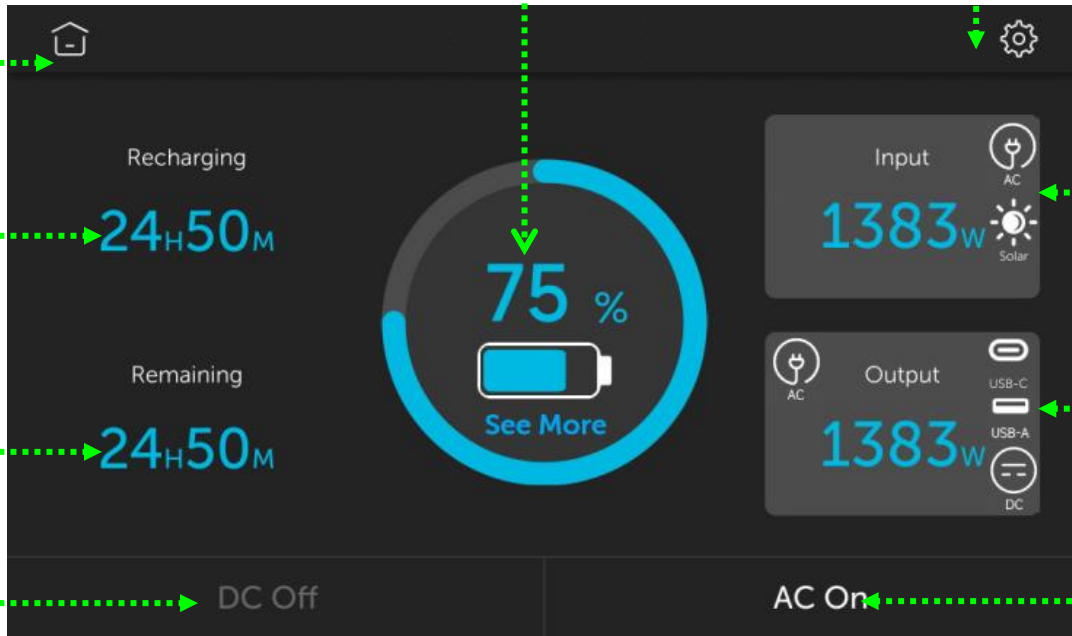

Charging Input Status and Parameters Page Button

Load Output and Parameters Page Button

AC Output Switch

3.2 Battery Information Page

The battery includes five status: 1. Disconnected, 2. Standby: the battery is connected and on standby, 3. Charging: the battery is connected and charging, 4. Discharge: the battery is connected and discharged, 5. Failure.

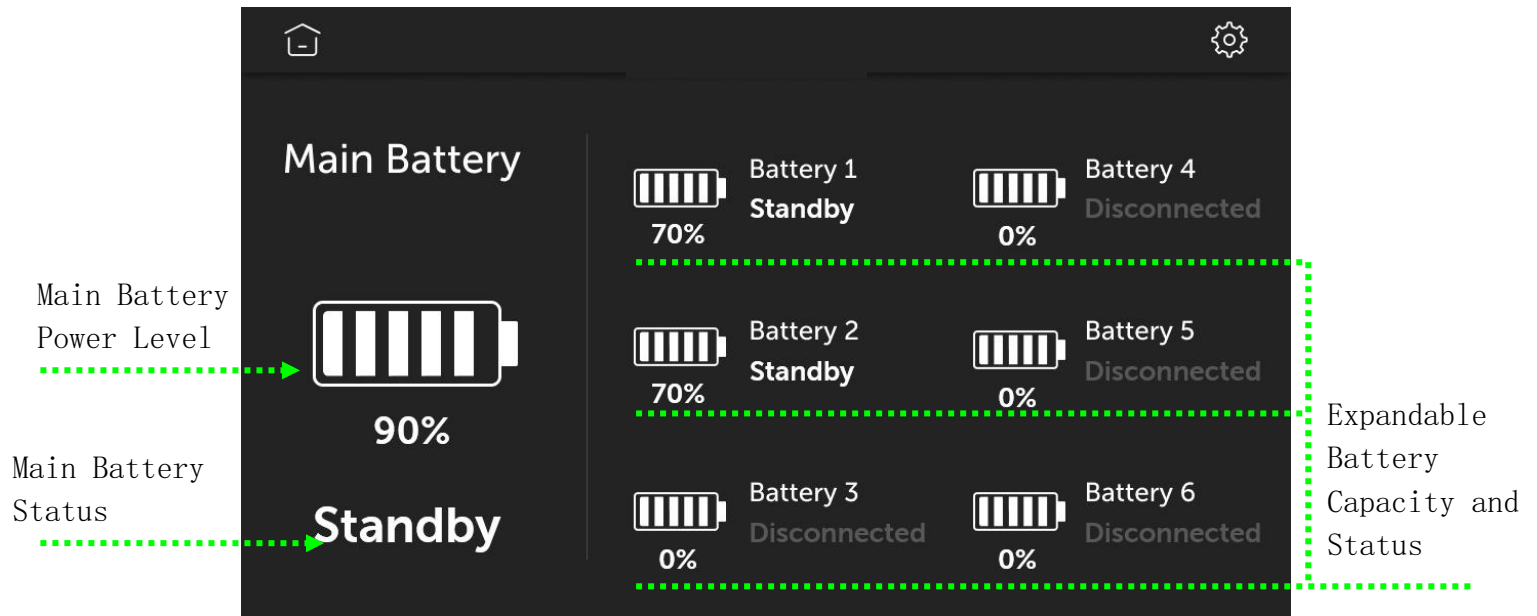

3.3 Charging Input Page

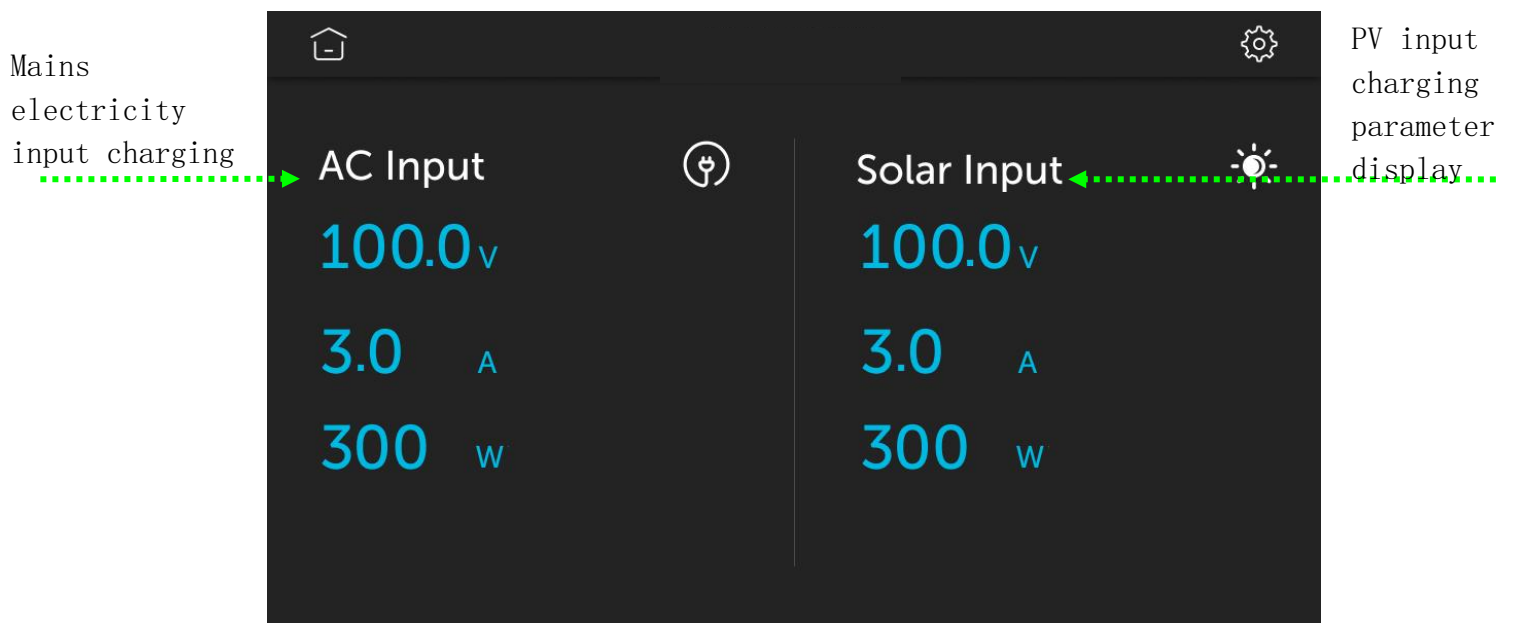

3.4 Load Output Page

USB/DC6 Load Output Parameters Display

AC Load Output
Parameters
Display

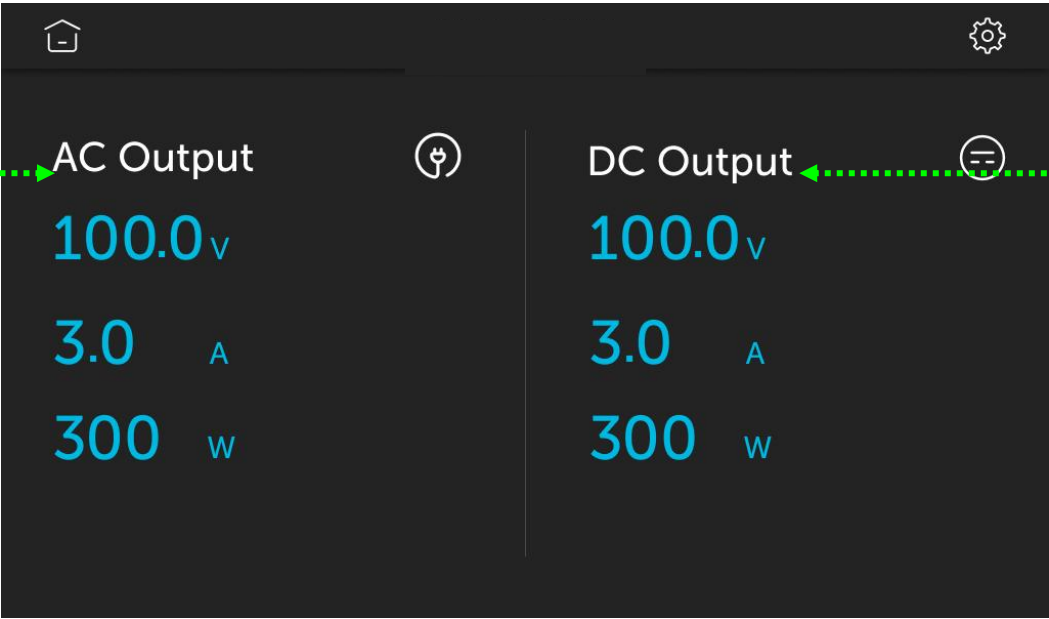

3.5 Setup Page

Return to Previous Page Button

Language Setting

Set the Screen
Sleep time

Touch Sound
Switch

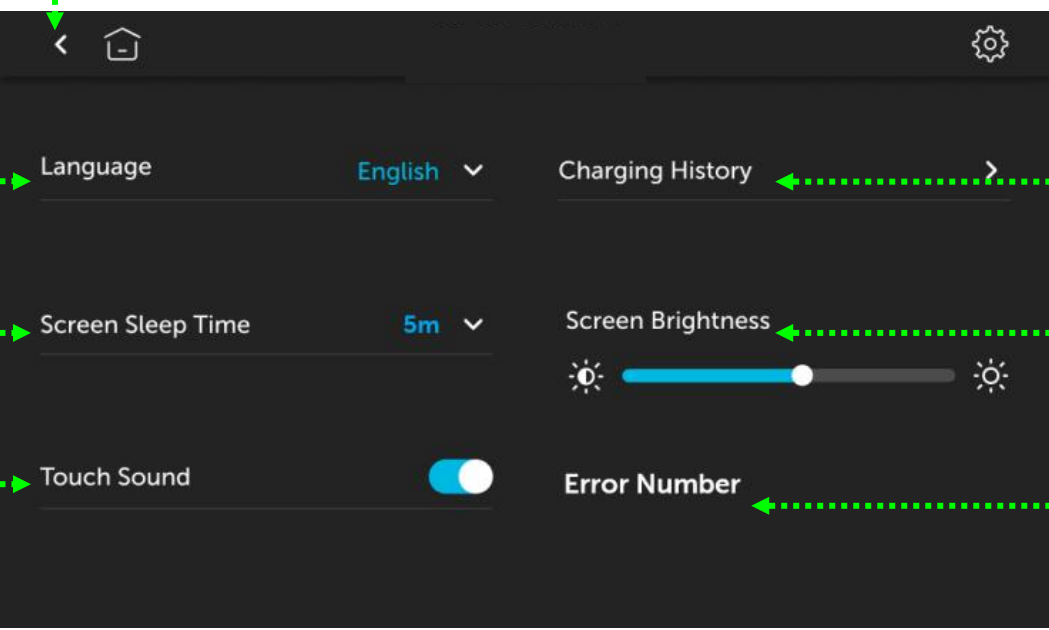

Charging
History

Screen
Brightness
Setting

Fault Code
Display

3.6 Language Settings Page

The product supports three language settings: English, French, Spanish (the default setting is English);

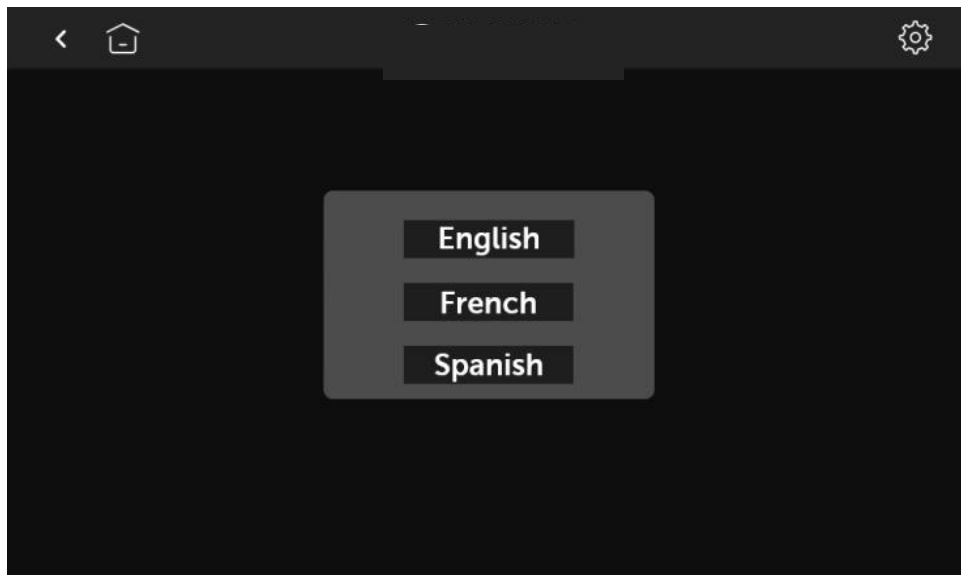

3.7 Screen Sleep Time Page

There are four Settings for the off time: 30 seconds, 1 minute, 5 minutes, and never (the default setting is 5 minutes);

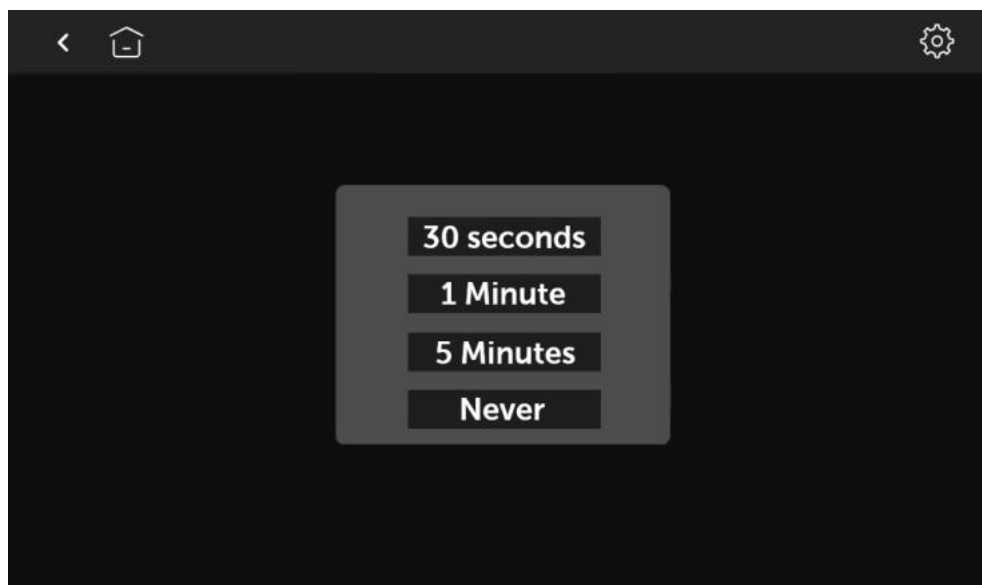

3.8 Charging History Page

The charging history record will save the charging capacity record of the previous seven days, and display the record according to the total charging power (Ah) of each day. In that case, only the data of seven days is displayed.

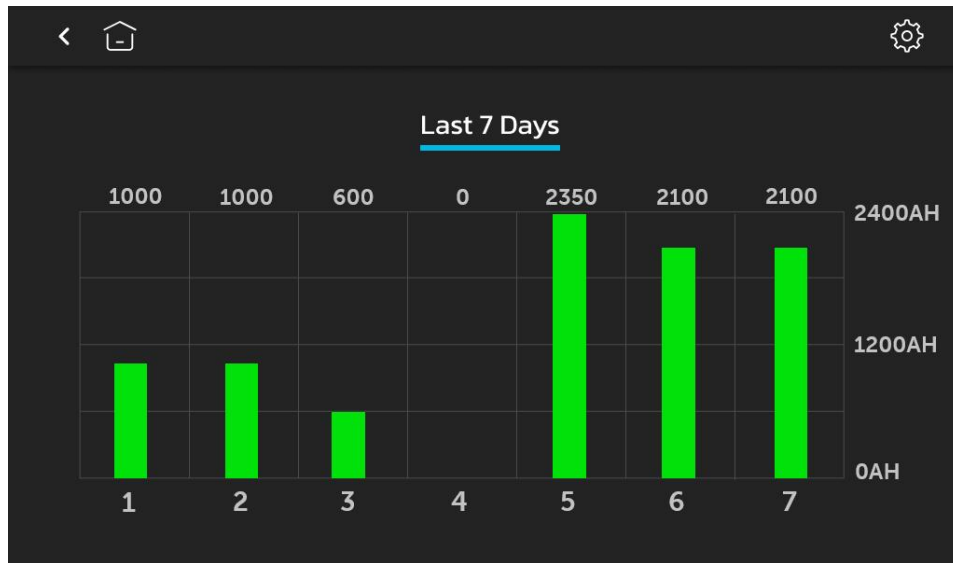

3.9 The Fault Icon Instructions

Fault icons are divided into high temperature, short circuit, and overload. If the product is in an abnormal state, the corresponding fault icon will appear on the screen. If you click the fault icon, there will be a troubleshooting prompt.

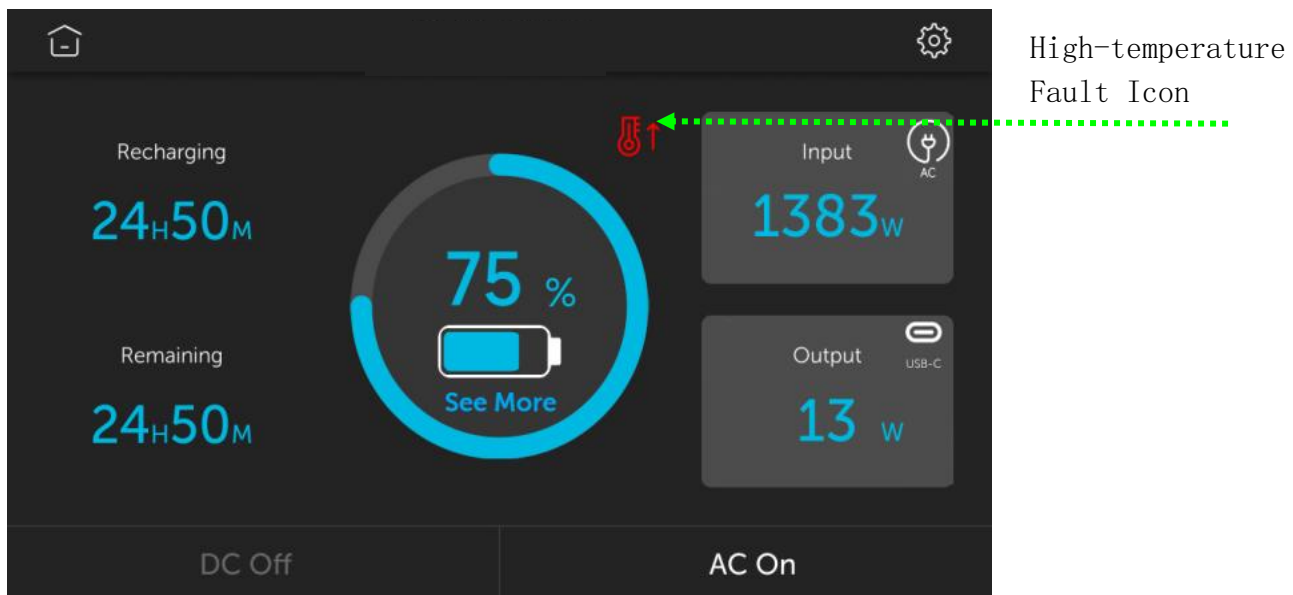

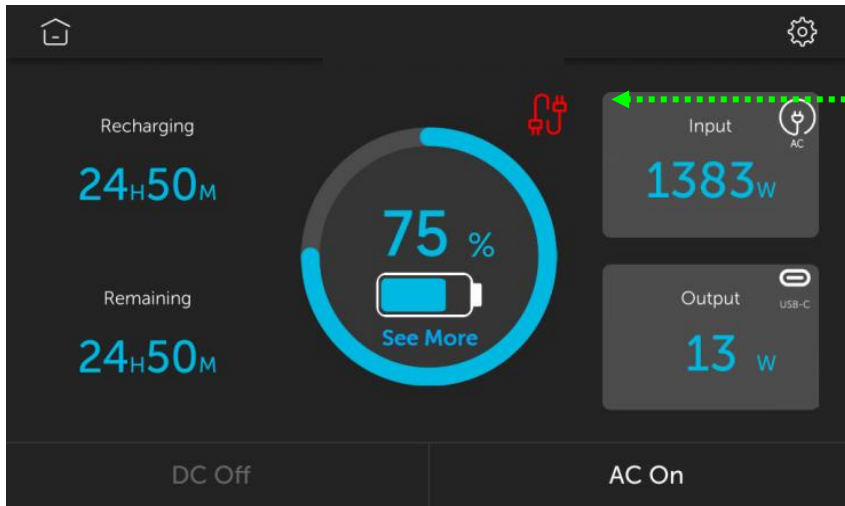

Short Circuit Fault Icon

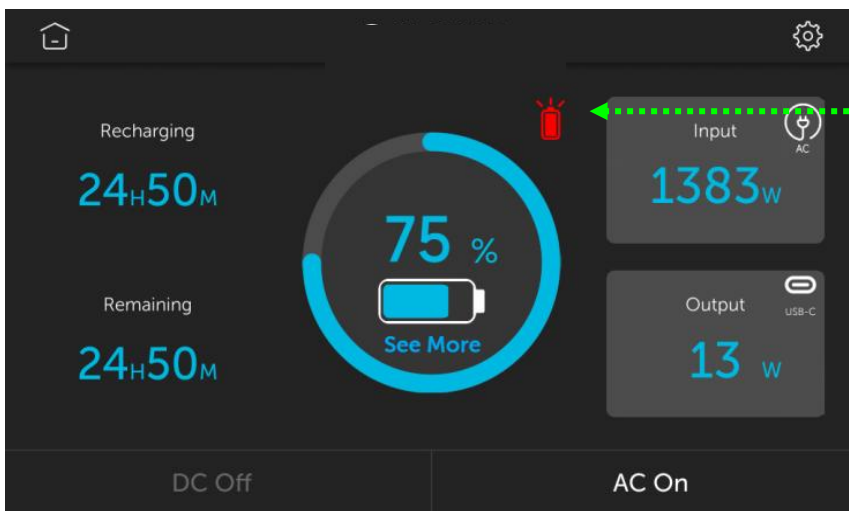

Output Overload Icon

3.10 Fault Code Display

The fault code can display four fault numbers at the same time, increasing from left to right. See Chapter 5 (Failure Code description table) for details about the meaning of the code.

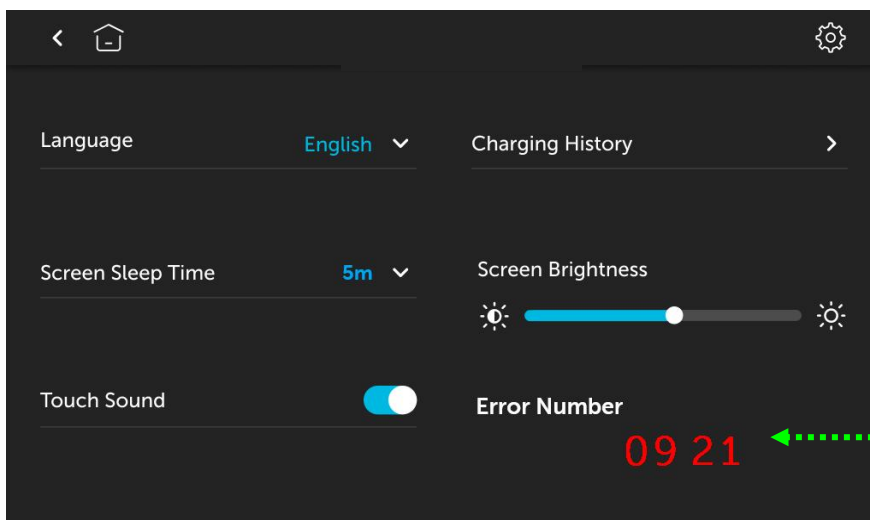

Fault Code Display

III、Technical Parameters

Item		Parameter
Nominal Power		3KW
Nominal Power		6KW
On-load Motor Capability		2HP
Battery Parameters		LiFePo4 51.2V 60AH
Battery Expansion		Supports the parallel expansion of up to 6 battery packs
Grid Connection		No
Product Size		840*750*872mm
Product Weight		121.5KG
Ambient Temperature Range		-10-40℃;Relative humidity: ≤80% ; Altitude≤2000m
Transport and Storage Environment		Temperature: -15-55℃; Relative humidity: ≤93% (no condensation) ; Atmospheric pressure: 70kPa~106kPa
Input	PV Charging	60-120V 50A Support MPPT Tracking function LP-28 Triangle Connector
	Mains Charging	110-120V 60HZ 2200W 20ATriangular Socket
Output	USB-A*4 Output	Independent 18W output*4: 5V3A 9V2A 12V1.5A Support QC3.0/QC2.0/AFC/FCP/BC1.2/APPLE and other fast charging protocols
	USB-C*2 Output	Independent 100W Output*2: 5V3A 9V3A 12V3A 15V3A 20V5A Support PPS/PD/QC3.0/QC2.0/AFC/FCP/BC1.2/APPLE and other fast charging protocols
	DC Output	5521 interface*2, cigarette lighter socket*1 12V10A
	AC Output	American standard socket L5-30*1 30A 125V 60HZ
	AC Output	American standard socket TT-30R*1 30A, 125V, 60HZ
	AC Output	American standard socket duplex GFCI 5-20R*3 20A, 125V, 60HZ
Charging Time	PV Charging	About 1.1H (3000W)
	Mains Charging	About 1.4H (2200W)
Support PV charging while discharging; do not support mains charging while discharging		

IV、 Operation and Usage

1. Steps for the First Start of Portable Power Station:

1.1 Turn on all circuit breaker switches at the side door.

1.2 Check whether there is any visible damage to the appearance of the station and whether the output interfaces are loose or damaged (If abnormal conditions occur, stop using)

1.3 Fix the grounding post on the back of the station to the ground.

1.4 Press the “POWER” button on the front panel, and if the green light comes on, it indicates that the startup has been successful. Observe whether the battery on the screen is fully charged. When the battery level is below 30%, it is recommended to fully charge it before use. When the product is powered on, the AC output defaults to on, and the DC/USB output defaults to off.

2. Charging Steps:

2.1 AC charging: First, confirm whether the mains grid voltage and frequency are within the range of mains charging input parameters of this product. Second, confirm that there is no load on the AC output socket, and plug one end of the AC charging cable in the accessory into the charging socket on the back of the power station. Then, check whether the charging power and remaining charging time on the screen correspond to the product parameters. During the charging process, the AC switch on the screen must be in the “ON” state. Otherwise, it cannot be charged.

2.2 Solar photovoltaic charging: Please check the photovoltaic input voltage range before charging. After confirming that the positive and negative poles of the input interface correspond correctly to the positive and negative poles on the product socket, insert the input interface into the photovoltaic charging socket at the bottom left corner of the power station. Then, turn on the POWER switch on the front panel and check if the photovoltaic charging power and remaining charging time displayed on the screen correspond to the product parameters. During the charging process, the POWER switch must be turned on. Otherwise, the product cannot be charged.

3. AC output On-load Usage:

AC on load: Before use, please check that the power range and voltage range of the on-load electrical equipment should match the output parameters of the equipment, and press the RESET button on the GFCI5-20R socket to open it; Check whether the short-circuiters at the side doors are all open. Insert the power plug of the loaded product into the output socket at the front of the power station, and turn on the AC switch on the front panel. The load should work normally. Check the output on-load power parameters on the display screen.

4. DC/USB Output On-load Usage:

Before using the power station, please check that the voltage and the

corresponding parameter range of the on-load electrical device are consistent with the power station. Insert the interface plug of the on-load electrical device into the corresponding interface in the front, and turn on the DC switch on the screen. The load should work normally. Check the output on-load power parameters on the screen.

5. Expanding Battery Usage:

Ensure that the specifications of the expandable battery are the same as those of the main battery. When the main and the expandable battery are off, insert one end of the expandable battery cable into the battery expansion port on the rear panel of the station and the other end into the socket in the expandable battery. Then turn on the portable power station and expandable battery switch in turn. Check whether the battery status in the main display is in normal status, and the capacity deviation range between the two batteries should be within 10% before expansion (otherwise, the battery life will be reduced and other battery failures will occur during use). The expandable battery can be charged independently by the charger equipped with the machine, or can be simultaneously charged by the mains and photovoltaic with the main battery;.

V、Fault Code Comparison Table

Fault Codes	Meaning	Description
01	BatVoltLow	Battery under-voltage alarm
02	BatOverCurrSw	Battery discharge average current overcurrent software protection
03	BatOpen	Battery not connected alarm
04	BatLowEod	Battery under-voltage stop discharge alarm
05	BatOverCurrHw	Battery overcurrent hardware protection
06	BatOverVolt	Charge overvoltage protection
07	BusOverVoltHw	Bus overvoltage hardware protection
08	BusOverVoltSw	Bus overvoltage software protection
09	PvVoltHigh	PV overvoltage protection
10	PvBoostOCSw	Boost overcurrent software protection
11	PvBoostOCHw	Boost overcurrent hardware protection
12	SpiCommErr	SPI communication failure between master and slave chips
13	OverLoadBypass	Bypass overload protection
14	OverLoadInverter	Inverter overload protection
15	AcOverCurrHw	Inverter overcurrent hardware protection
16	SlaChiReqShu	Slave chip requests shutdown fault
17	InvShort	Inverter short-circuit protection

19	OverTemperMppt	PV radiator over temperature protection
20	OverTemperInv	Over temperature protection of inverter heat sink
21	FanFail	Fan failure
22	EEPROM	Memory failure
23	ModeNumErr	Model setting error
24	Busduff	Positive and negative bus voltage imbalance
25	BusShort	Bus short circuit
26	RlyShort	Inverted AC output backflow to bypass AC output
28	LinePhaseErr	Mains input phase error
29	BusVoltLow	Bus voltage low protection
30	BatCapacityLow1	Battery capacity rate below 15% alarm
31	BatCapacityLow2	Battery capacity rate below 5% alarm
32	BatCapacityLowStop	Battery low capacity shutdown
58	BMSComErr	BMS communication failure
59	BMSErr	BMS error
60	BMSUnderTem	BMS low temperature alarm
61	BMSVoerTem	BMS over temperature alarm
62	BMSOverCur	BMS overcurrent alarm
63	BMSUnderVolt	BMS under-voltage alarm
64	BMSOverVolt	BMS overvoltage alarm

VI、 Product Maintenance

- 6.1 Newly purchased products should be fully charged before use;
- 6.2 Regularly remove dust and dirt from the cooling window;
- 6.3 In the case of long-term storage for more than three months, not less than 50% of the power storage shall be maintained;
- 6.4 If stored for more than 6 months, to extend the service life of the battery, please charge and discharge the product 1-2 times;
- 6.5 Regularly add wheel lubricant;
- 6.6 Scrub the surface of the chassis after each outdoor use;
- 6.7 Regularly check whether the external screws and lifting rings of the chassis are fully tightened;

VII、 Common Troubleshooting

7.1 Unable to Perform Mains Charging:

- A、 If the mains input voltage range and frequency exceed the parameter range of the power station, it cannot be charged.
- B、 The AC switch in the screen should be in the open status. If the AC switch is closed, it cannot be charged.
- C、 Check whether the specifications and models of the charging cable are consistent with those equipped with this power station and check whether there is an open circuit.

D、 When charging, the AC output socket should not be plugged into the load, otherwise, it cannot start charging.

7.2 Unable to Perform Photovoltaic Charging

A、 Check whether the voltage range and current of the photovoltaic panel are within the parameter range of the power station.

B、 Make sure to use it in sufficient light.

C、 Before PV charging, the POWER switch should be turned on first so that the power station can be charged under the startup state.

D、 Check whether the photovoltaic circuit breaker out of the side door is open.

E、 Check whether the positive and negative poles of the photovoltaic panel connection line correspond to those on the product socket, and the plug and socket should match.

F、 Check whether the photovoltaic panel connection line has broken or is in an open circuit situation;

7.3 Unable to Perform AC load::

A、 Check whether the AC icon button in the display is open.

B、 The circuit breakers at the side door of the product should all be turned on.

C、 The RESET button on the GFCI5-20R socket should be turned on and the green indicator should be lighting.

D、 Confirm whether the power of the load appliance is within the normal load range of the power station.

7.4 USB/DC No-output:

- A、 Check whether the DC icon button on the display is open.
- B、 Check whether the load connection line is in an open circuit situation.
- C、 Check if the output interface is fully inserted and firmly connected.

7.5 After turning on the main power switch of the power station, the product cannot start normally and the display screen doesn' t work:

In this case, it should be considered that the product battery may be out of power, the internal reverse controller cannot be started, and the battery enters a state of power loss sleep. You can first access the mains to charge the product and activate it. When the battery is fully charged, it can be used.

7.6 Unable to Connect the Expandable Battery:

- A、 The power switch of the expandable battery should be opened.
- B、 The specifications, models, and parameters of the expandable battery must be consistent with the main battery;
- C、 Check whether the plug of the expansion connection line is completely inserted into the expansion socket;
- D、 Measure and exclude whether the expansion line has an open circuit situation;

VIII、Warnings and Precautions

8.1 Different electrical appliances have different voltage standards. Before use, please carefully check whether the rated voltage range of the product is consistent with the voltage range of the portable power supply, otherwise, it may lead to dangerous situations;

8.2 After the battery is discharged to the cut-off voltage, continuing to discharge is called over-discharge. It can easily cause serious power loss in the battery, thereby greatly shortening its service life. Therefore, deep discharge should be avoided as much as possible when using the battery;

8.3 The product should be kept away from fire, high-temperature environments, and humid and rainy environments during use and storage, otherwise it may lead to dangerous situations;

8.4 This product has a built-in high-voltage power supply, and non-professionals should not disassemble it by themselves;

8.5 Do not discard the product at the end of its service life. Recycle the product according to local laws and regulations;

8.6 This product should be protected from rain, water immersion, and violent vibration during transportation;

8.7 It cannot be used at an altitude exceeding 2000m;

8.8 The product is AC output. Please do not insert your hands or hand-held metal conductors into the AC socket;

8.9 Do not drop, squeeze or collide with the product, so as not to subject the product to external pressure, which may cause a short circuit of the internal circuit of the product and damage to the battery;

8.10 After use, please turn off the machine in time (the no-load power consumption will continue to consume battery power when the machine is on);

8.11 Please select solar panels according to the electrical parameters specified by the manufacturer. If the voltage is above these parameters, it may damage the product;

8.12 Prohibit products from using AC output loads during AC mains charging (The charging socket is 20A and can only withstand charging Current). Otherwise, it will cause security risks;

8.13 This product and its accessories may contain some small parts. Please keep the product and its accessories out of the reach of children. Children may accidentally damage the product and its accessories, or swallow small parts, causing suffocation or other dangers, children or people with mental retardation need to use this product accompanied by their guardians;

8.14 Do not use the product during thunderstorms. This may cause product failure or electric shock;

8.15 If the product accidentally falls into the water during use, place it in a safe open area and do not turn it on again;

8.16 When transporting and lifting products, it is necessary to ensure that the lifting rings are tightly and firmly installed, otherwise safety accidents may occur;

8.17 When using the expandable battery, ensure the deviation range of the battery capacity between batteries is within 10%. Batteries of different specifications and manufacturers cannot be used; otherwise, the product may be damaged and security risks may arise;

8.18 Please use the charger, charging cable, and photovoltaic charging interface provided with the product to charge the product, otherwise there will be security risks;

8.19 The product must be securely and effectively grounded before use;

8.20 If any fault occurs during the use of the product, it should be stopped immediately, and can be used only after the troubleshooting is complete, otherwise it will cause damage to the product;

8.21 All input and output socket covers shall be closed after use;

8.22 Do not touch any of the ports on the product with your hands or metal devices while the station is on. Otherwise, there will be a safety hazard.

IX、 Product Packing List

9.1 Portable Power Station*1

9.2 Product manual*1

9.3 Diagonal 3mm hex wrench*1

9.4 AC Power Supply Charging Cable*1

9.5 TT-30P Plug *1

9.6 Photovoltaic Charging Connector*1

9.7 L5-30 Plug*1

9.8 17mm Fork Wrench*1

9.9 Cigarette Lighter to 5521 Interface Connection Cable*1

**Production address: NO.55 Dingda Road, Yingquan Economic Development Zone,
Fuyang Anhui, China**

Tel: 0558-7159979

Fax: 0558-7159988

Postcode: 236000

Date of production: Please refer to the package.

Service life: 5 years

The date of compilation of the manual: Jun 21st, 2023